

Support cylindrique

Description de l'article/illustrations du produit



Description

Matière :

Acier de traitement.

Finition :

Corps de base : bruni.

Doigt : trempé et bruni.

Indication de dessin :

J = Vis de montage

L = Vis à bille orientable

M = Vis à six pans creux

1) Vis support

2) Ecrou

3) Vis à bille orientable

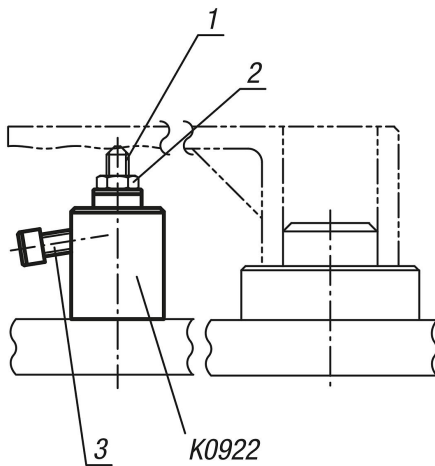

Support cylindrique

Dessins

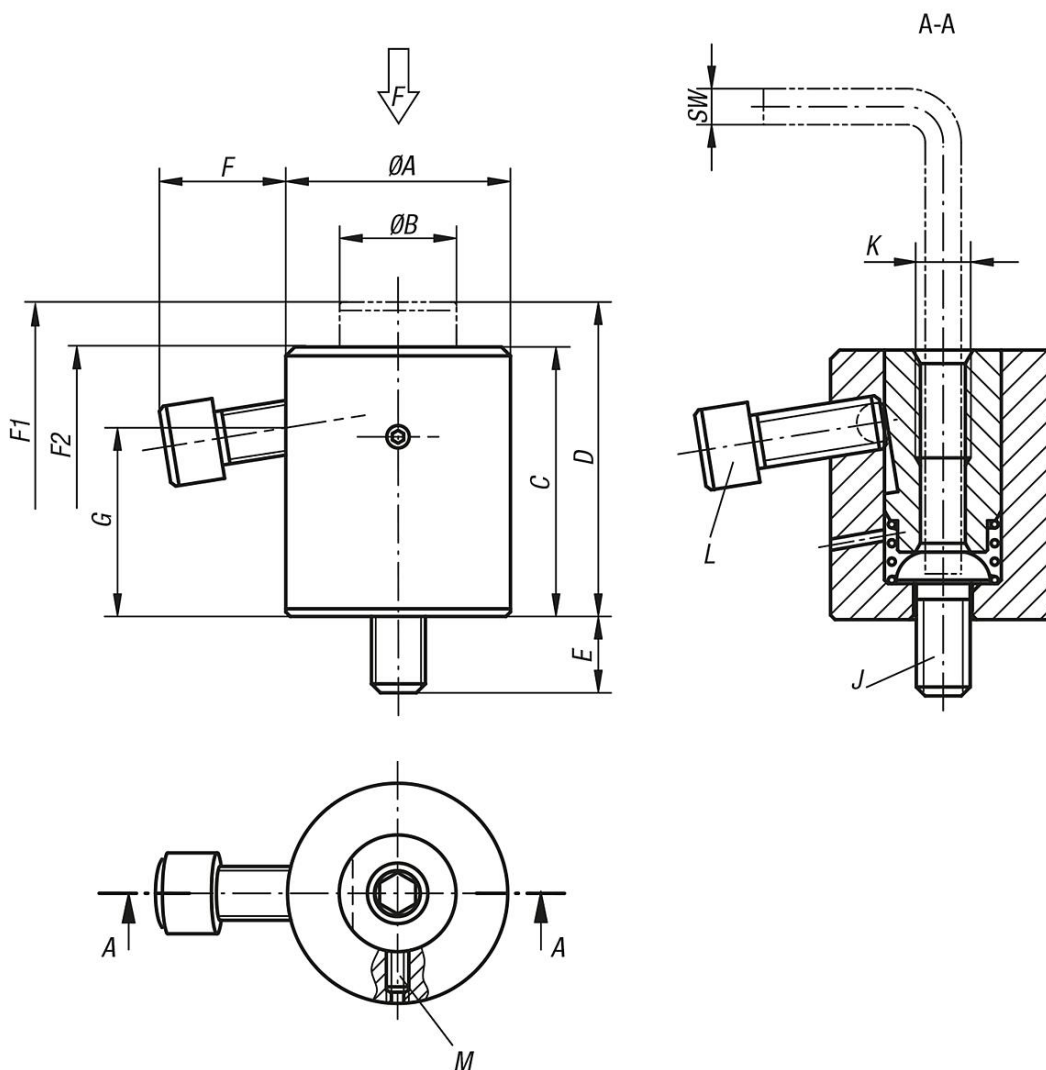

Aperçu des articles

Support cylindrique

Référence	A	B	C	D	E	F	G	J	K	L	M	SW	F N	Force du ressort initiale F1 env. N	Force du ressort finale F2 env. N
K0922.06039	28	14	33	39	10	14,1	22	M6	M6x12	M6x16	M4x8	4	4000	10	22
K0922.08052	35	19	42	52	15	18,8	28,5	M8	M8x16	M8x20	M4x8	5	6000	10	27
K0922.12070	50	26	60	70	17	28,5	42	M12	M12x24	M12x30	M5x12	8	9000	15	30
K0922.16080	60	33	70	80	22	26,5	47	M16	M16x32	M12x30	M5x15	10	9000	15	35